

## C2000 CRYOGENIC VALVE SERIES

# Model C2043-M21

- 1/2" IPS Pipe Size Cryogenic Valve
- Manual Operation
- Vacuum Jacketed
- Y-Pattern Style Body

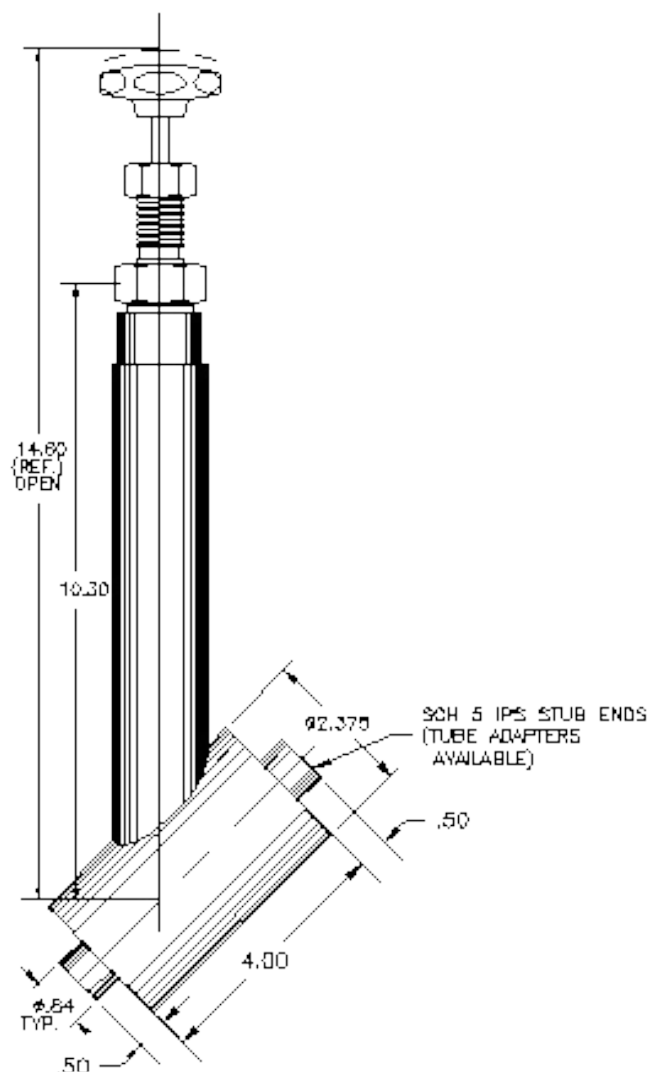

## FEATURES

- Low Handle Torque For Bubble Tight Shut-off
- Stainless Steel Body, Stem and Threads
- Redundant Stem Seal
- Cryogenic Stem Packing
- Brass Bonnet
- Redundant Cryogenic Bonnet Seal
- Bonnet Purge Port (Thermal Relief Location)
- Tight Fit Stem
- MLI on Jacketed Valves
- Brass Plug
- Plug To Stem Stabilizer
- KEL-F Seat Seal w/ Locked Thread Insert
- Contoured Flow Plugs Available

## TECHNICAL DATA

- 300 PSI MAWP (Maximum Operating Pressure)
- Seat Seal Bubble Tight @ 150 PSIG
- Packing Mass Spec Tested @  $1 \times 10^{-5}$  Torr
- Leak Rate Below  $1 \times 10^{-9}$  CC GHe/SEC
- Heat Leak: 4.5 BTU/HR To 20° K
- Cooldown Mass: 0.65 Pounds
- Options:
  - Cold Box Jacket
  - Pneumatic Actuators
  - Purge Port

## APPLICATIONS

- Vacuum Jacketed Piping
- Cold Boxes
- Manifold and Tank Systems
- Liquid Nitrogen, Argon and Oxygen Service (with Proper Cleaning)