

TECHNICAL DATA:

1. 300 PSI MAWP
(Maximum Operating Pressure)
2. Seat Seal Bubble
Tight @ 150 Psig.
3. Packing Mass Spec
Tested @ 1×10^{-5}
Torr Vacuum. Leak
Rate Below 1×10^{-9}
Cc Ghe/sec.
4. Heat Leak :
4.5 Btu/hr To 20°k.
5. Cooldown Mass:
0.85 Pounds.

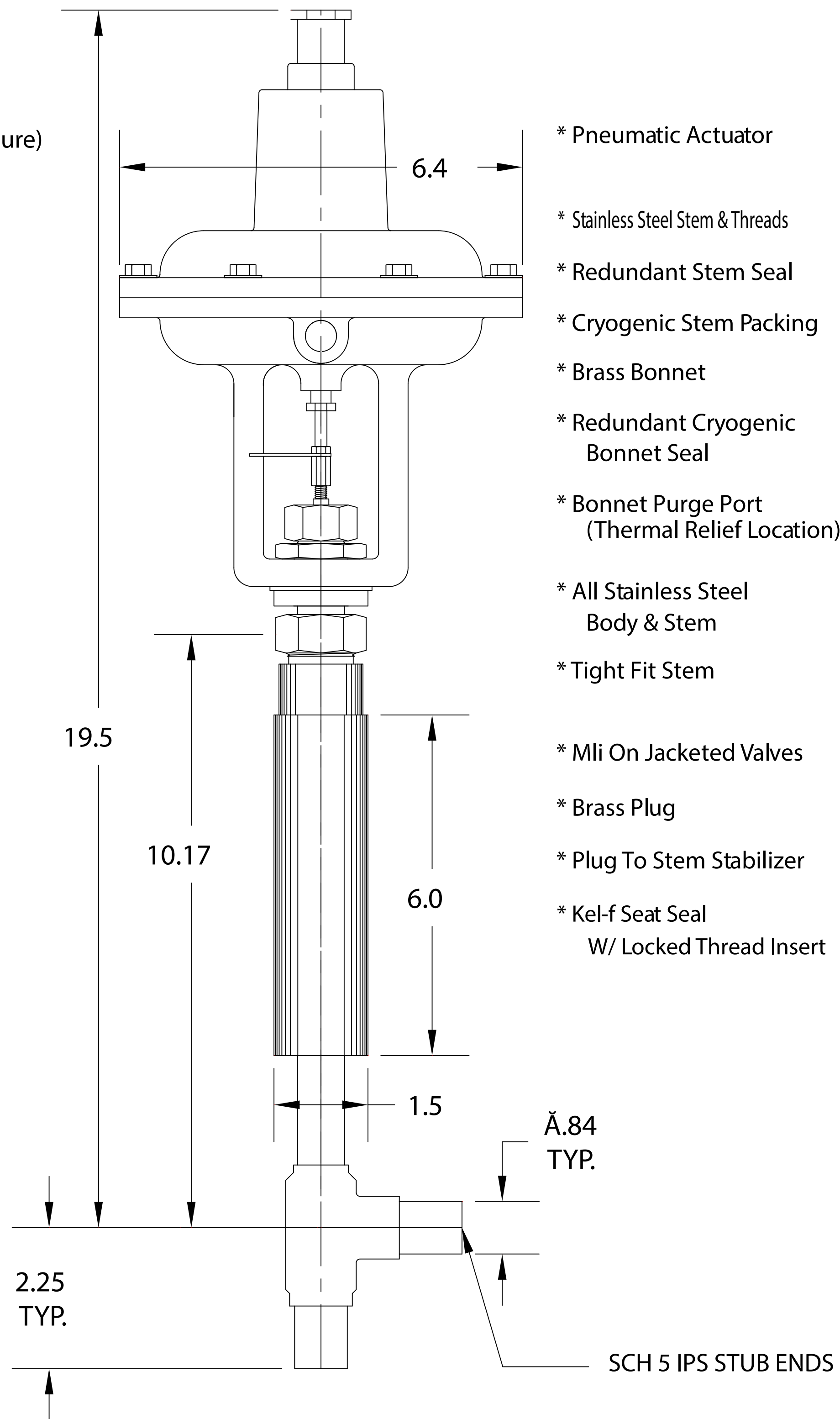

1/2"IPS CRYOGENIC VALVE

W/PNEUMATIC ACTUATOR

CRYOCOMP
CRYOGENIC AND VACUUM COMPONENTS

DATE:
12/22/03

DWG NO.
C2042-A23