

SPECIALTY PRODUCTS

H1300 Vapor Vent Heater

The H1300 Vapor Vent Heater is designed for installation on the outlet of any mechanical vapor vent to warm the exhaust gas to room temperature eliminating condensation and ice on the piping.

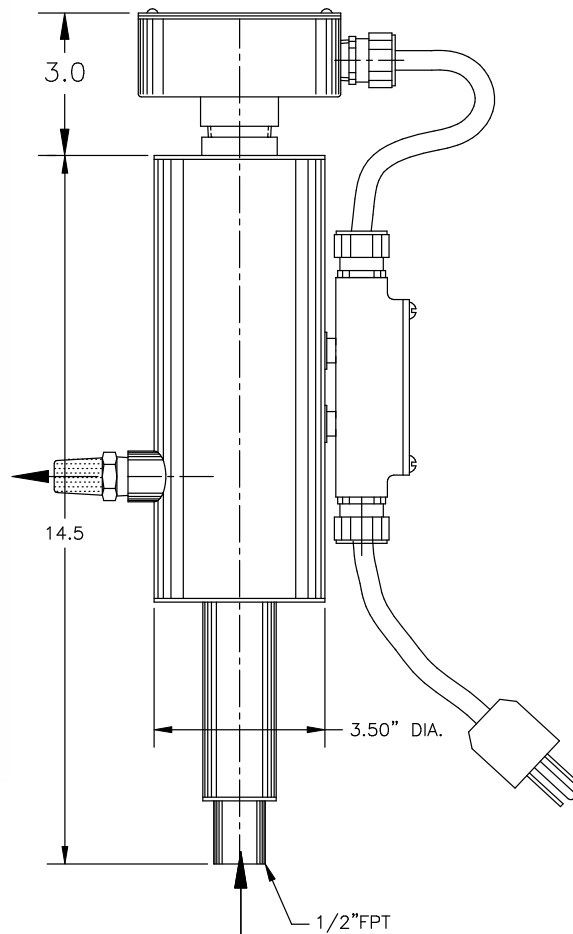

FEATURES

- Installs on The Outlet Of Any Liquid Nitrogen Keepfull Device
- Eliminates Ice Formation on Vent Piping.
- Eliminates Need For Insulation on Vent Piping
- Eliminates Need For Vent Piping In Large Room Discharge Area.
- No More Condensate Drip on Floor and Ceiling Tiles.

TECHNICAL DATA

- 110 Vac/375 Watts or 220 Vac/375 Watts
- 500 Watts Option
- Line Cord Provided
- Over Temp Switch Included
- 1/2" FPT Inlet and Outlet

IMPORTANT SAFETY ACCESSORY

- Heater Guard H-100-HS

**To Avoid Injury:
Cryocomp strongly recommends
the H-100-HS Heater Guard be
purchased and installed with
the H1300 Heater.**



CRYOGENIC VALVES and VACUUM COMPONENTS

sales@cryocomp.com ▼ 276.728.2064 ▼ www.cryocomp.com

a division of Cryofab, Inc.

