

## C3000 LIQUID HELIUM VALVE SERIES

# Model C3041-M21

### • 1/2" LHe Globe Valve

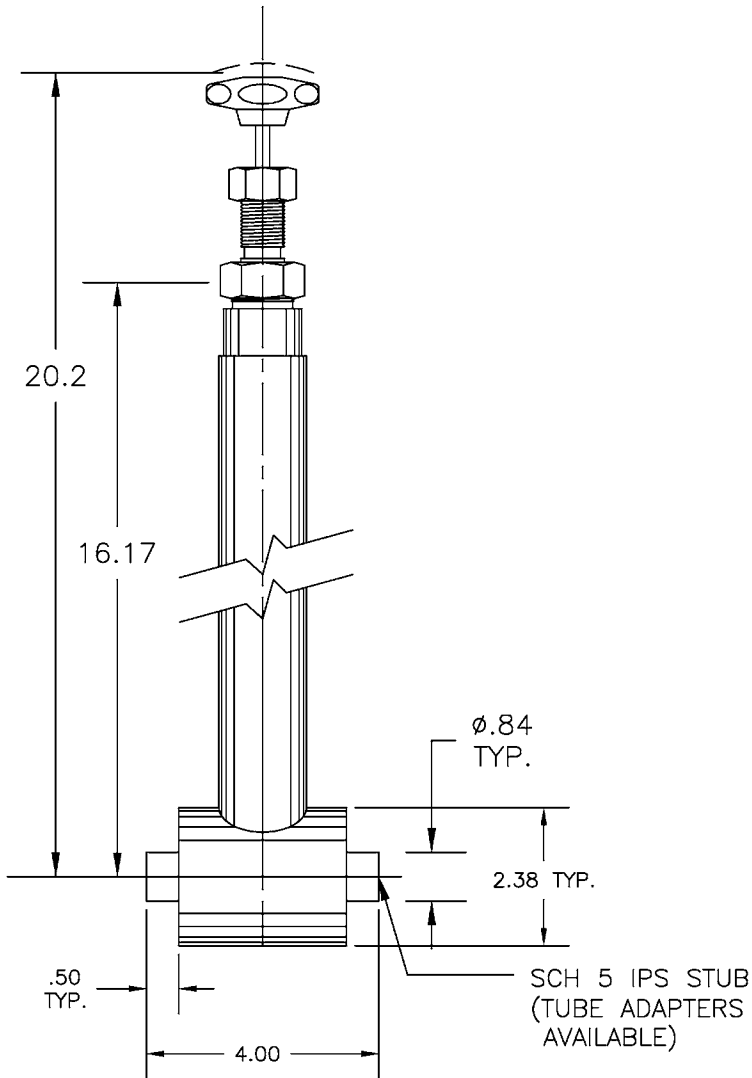

### FEATURES

- Manual Actuation
- Redundant Stem Seal
- Cryogenic Stem Packing
- Brass Bonnet
- Redundant Cryogenic Bonnet Seal
- Bonnet Purge Port (Thermal Relief Location)
- All Stainless Steel Body & Stem
- Cold Box Cuff (Full Jacket Available)
- MLI On Jacketed Valves
- Low Thermal Conductivity Stem & Support Tube
- Brass Plug
- Plug To Stem Stabilizer
- KEL-F Seat Seal w/Locked Thread
- Contoured Flow Plugs Available

### TECHNICAL DATA

- 150 PSIG MAWP  
225 PSIG Proof
- Seat Seal Bubble Tight @150 PSIG
- Packing Mass Spec Tested @  $1 \times 10^{-5}$
- TORR. Leak Rate Below  $1 \times 10^{-8}$  CC GHe/SEC.
- Seat Seal Helium Bubble Tight Tested @ 150 PSIG @ Ambient Temp.
- Heat Leak: 3.5 BTU/HR.(1 Watt)
- Cooldown Mass: 0.75 Pounds.

### APPLICATIONS

- Vacuum Jacketed Piping
- Cold Boxes
- Helium Transfer Lines
- Helium Liquefiers



CRYOGENIC VALVES and VACUUM COMPONENTS

sales@cryocomp.com ▼ 276.728.2064 ▼ www.cryocomp.com

a division of Cryofab, Inc.

