

V2000 VACUUM SEAL-OFF VALVE AND OPERATOR SERIES

V2000 Series Seal-off Valve

The V2000 vacuum seal-off valve is a high conductance, compact and highly reliable means of providing an evacuation entry into any large vacuum system. The valve incorporates a spring loaded poppet which provides relief in the event of an over pressure, protecting an inner vessel or neck seal. The poppet and spring assembly is installed after the body is welded to the vacuum space.

The V2000 is used with a valve operator to connect to a vacuum pump and is removed after the evacuation process is finished. The valve operator stem engages the poppet and the handle is toggled up to pull the poppet open and begin the evacuation. After the evacuation is complete, the handle is toggled down and the poppet re-seats providing a vacuum tight seal. The stem is then disengaged from the poppet and the valve operator is removed to complete the operation.

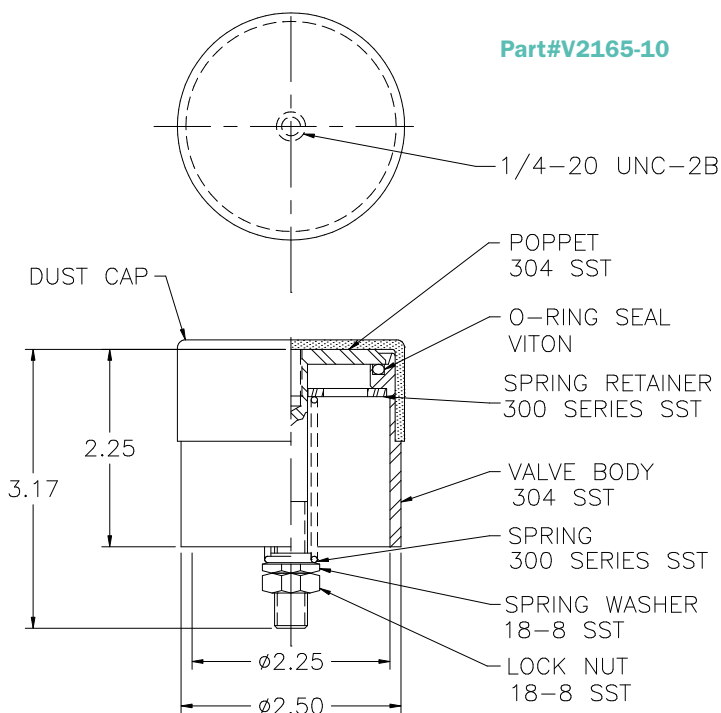

TECHNICAL DATA

- Vacuum Leak Tested @ 1×10^{-5} TORR
Leak Rate Less Than 1×10^{-9} SCC GHe/SEC
- Relief Pressure 2-6 PSIG.
- Uses Valve Operator P/N V2165-20.
Optional V2165-30-50 with KF-50 outlet flange.
- TC Vacuum Tube Port Available – P/N V2165-11
- **CONNECTION:** Weld jacket is standard.
Thread and ISO flange connections available
on special request.

APPLICATIONS

- Cryogenic Tanks and Dewars
- Vacuum Insulated Piping
- MRI Magnet Vacuum Containers