

C2000 CRYOGENIC VALVE SERIES

Model C2082-M21

- 1" IPS Pipe Size Cryogenic Valve
- Manual Operation
- Vacuum Jacketed
- Right Angle Style Body

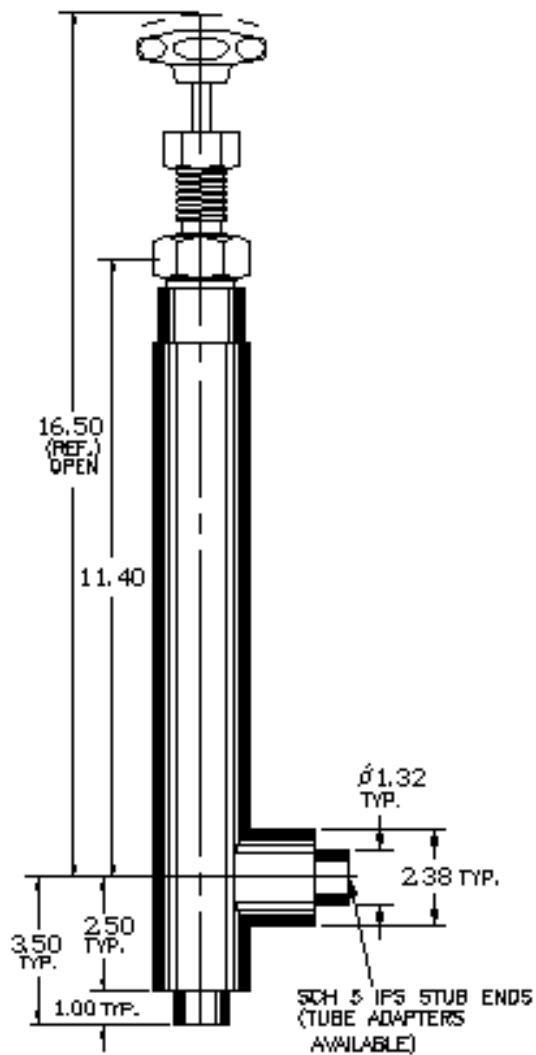

FEATURES

- Low Handle Torque For Bubble Tight Shut-off
- Stainless Steel Body, Stem and Threads
- Redundant Stem Seal
- Cryogenic Stem Packing
- Brass Bonnet
- Redundant Cryogenic Bonnet Seal
- Bonnet Purge Port (Thermal Relief Location)
- Tight Fit Stem
- MLI on Jacketed Valves
- Brass Plug
- Plug To Stem Stabilizer
- KEL-F Seat Seal w/ Locked Thread Insert
- Contoured Flow Plugs Available

TECHNICAL DATA

- 300 PSIG MAWP
450 PSIG Proof
- Seat Seal Bubble Tight @ 150 PSIG
- Packing Mass Spec Tested @ 1×10^{-5} TORR Vacuum
- Vacuum Leak Rate Below 1×10^{-9} CC GHe/SEC
- Heat Leak: 10.4 BTU/HR To 20°K
- Cooldown Mass: 1.75 Pounds
- Options:
 - Purge Port
 - Cold Box Jacket
 - Pneumatic Actuators

APPLICATIONS

- Vacuum Jacketed Piping
- Cold Boxes
- Manifold and Tank Systems
- Liquid Nitrogen, Argon and Oxygen Service (with Proper Cleaning)